



SEMI-AUTOMATIC GAS PISTOL

SIZE : S / M / L

FOR GAS MAGAZINE



INSTRUCTION MANUAL

P08

GAS POWERED AIRSOFT GUN

GAS FULL PRESSURE AUTO BLOWBACK GUN

FOR AGE 18 YEARS OR OLDER

MADE IN TAIWAN

① 各部名稱 NAME OF PARTS



② 安全裝置(保險片)的使用方式 OPERATION OF THUMB SAFETY

■ 保險 (安全裝置)
Safety (protection device)

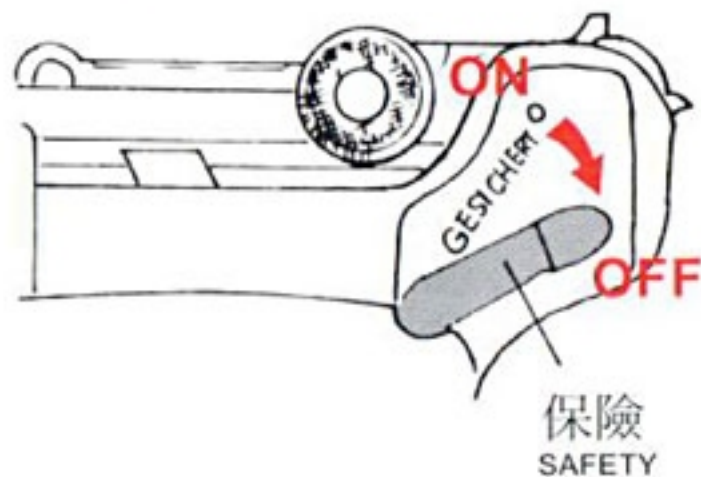

③ 裝填BB彈 LOADING BB BULLET

■ BB彈裝填
裝填BB彈6m/m(14+1發入)
Loading BB bullet
Load BB bullet in the magazine, 6 mm (14+1 rounds only)

■ 請依照圖示之排列方式裝填BB彈
Please follow the illustrative sequences to load the BB bullets.

- 拉下上彈托板自彈匣槽口, 填入6MM BB 彈 (可填入15發)

Press the magazine follower and load the 6mm BB bullets along the magazine slot (full loaded 15 rounds)

- BB 彈裝填時可用手指阻擋後方入彈孔以利快速填彈

While loading, put finger at the back hole to speed up loading

- ▲ 使用6MM直徑真圓度良好之正規BB彈以防止槍枝毀損
Using the standard 6mm diameter really round bullet to prevent damage to the barrel

- ▲ 使用不良BB彈, 會造成槍枝動作不順或無法擊發狀況
Nonstandard bullet would render poor function or no fire.

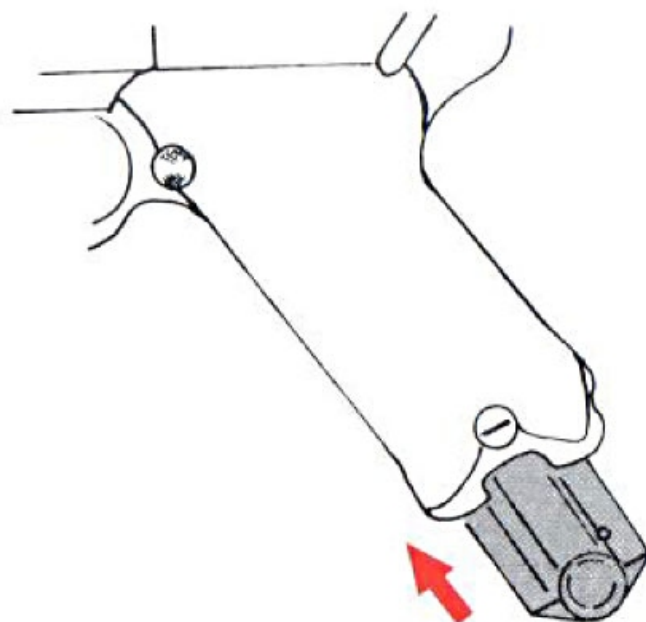
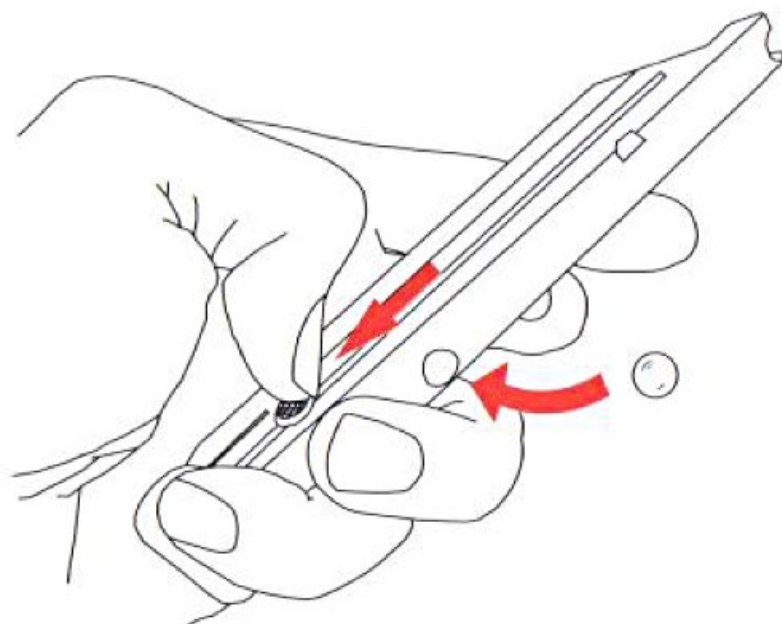

請勿使用超過6mm、表面不平整、或使用過之BB彈

Please do not use the BB bullets that are over 6mm, rough on surface or have been used.



! CAUTION !

④ 瓦斯灌注方式 REFILLING GAS

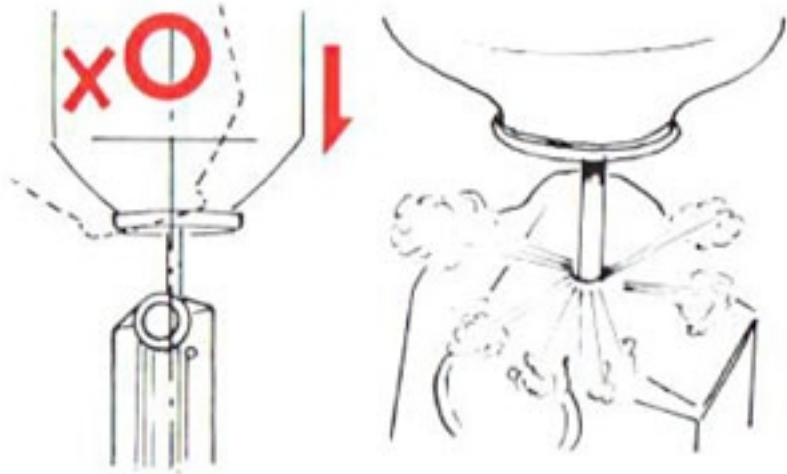

- 將彈匣底板朝上將專用瓦斯灌嘴對正注入孔按壓約2-3秒

Place the magazine base upward, use authorized gas container, align the injector to the filler, and press downward. It takes about 2~3 seconds to complete the refilling

- ▲ 必須使用專用瓦斯, 任意填充其他氣體易造成危險
Refill with gas only. Unauthorized gas would cause incident

- ▲ 釋放出的瓦斯氧化揮發時, 會造成彈匣溫度下降而無法擊發; 需待恢復至常溫狀態下即可使用

The refilled gas is volatile which will freeze the magazine. The pistol will come to operation when the magazine recovers to the normal temperature

- ▲ 填充瓦斯不可放至於高溫等場所(40°C以上), 如太陽直曬高溫車內, 火源附近及暖氣設備
Never store the gas container in the place where the temperature is above 40°C, such as direct sunlight, inside car, fire and hot air conditioner

⑤ 上彈匣 LOADING & RELEASING THE MAGAZINE

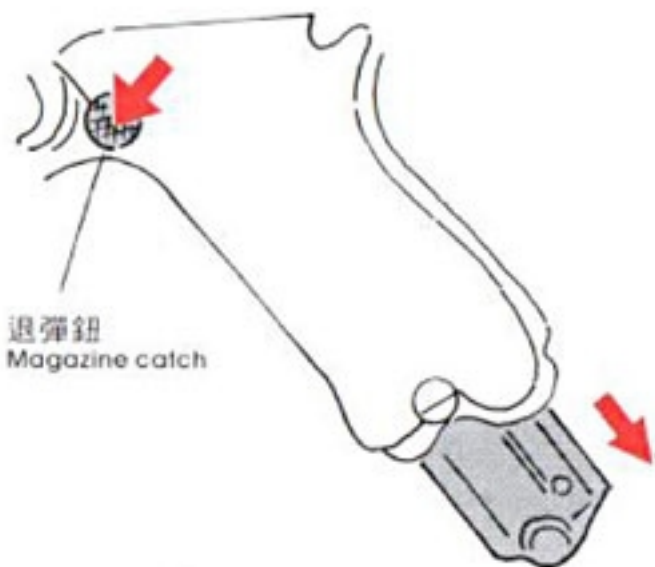

- 先按下彈匣卡筭取出彈匣
Press the magazine catch and take off the magazine.

- ▲ 取彈匣時務必在擊鎚處於一般狀態下才能取下
The magazine can be taken off only when the hammer is placed at the normal position

- ▲ 由於彈匣屬於金屬材質重量, 小心按下卡筭時掉落造成摔壞或其他物品損傷。

The magazine is made of metal material, care shall be taken not to let it fall on the ground and cause damage.

⑥ 上膛-第一次射擊上彈 FIRST LOAD FOR FIRING

■ 第一次射擊之送彈

初次擊發時需將滑套往後退至定點放開後滑套向前上膛擊錘卡於後方即可發射

First load of bullet for firing

Pull the slide backward to a specific position, then release and let the slide moving forward to load the bullet in the firing chamber, and retain the hammer at the rear position, ready for firing.

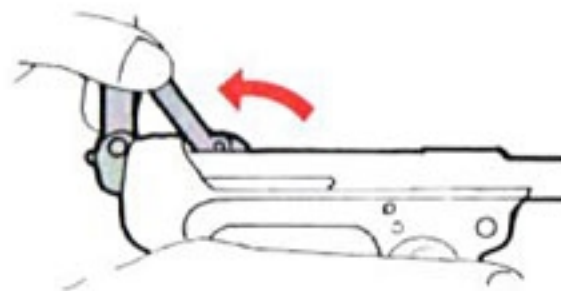

- 將填入瓦斯及BB彈完成之彈匣裝入槍身中
Insert the gas filled and bullet loaded magazine into the frame receiver

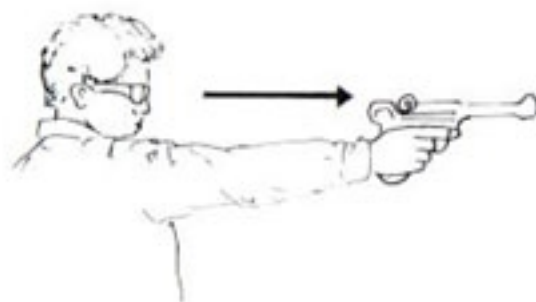

- 也可以先扳下擊錘瞄準射擊(複動模式)
Pull down the hammer and take aim (repeated action).

- 瞄準目標(開保險)扣板機射擊
Aim the target, release the thumb safety, and pull the trigger to fire

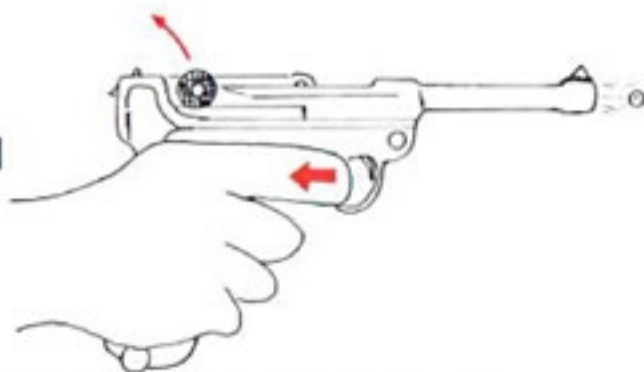

⑦ 注意事項 PRECAUTION

- 不可交予未滿18歲以下人員單獨使用
Never allow the kid under 18 using the BB pistol alone
- 射擊前務必戴上護目鏡注意並確認週遭環境不會誤傷他人
Always wear goggles while firing. Pay attention never let any person around the firing range.
- 無論有無保險均不得指向人 動物
Never point the pistol to any person and animal regardless whether the thumb safety is on or not.
- 非準備射擊時手指不得伸入護弓
Never extend the finger into the trigger guard while it is not ready to fire.

- 長時間存放後,要取出使用時,先檢視全槍機件是否正常作動,是否正常順暢,適當的潤滑保養可維持機件壽命及作動順暢度。

After long time storage, check all mechanical function of all parts and apply adequate lubricant to maintain the service life span and smooth performance.

- 使用完畢後,務必清檢確認沒有BB彈殘留於槍膛中,拔下彈匣清除所有彈匣內BB彈,釋放多餘瓦斯,將槍,彈匣及BB彈分別收放到包裝盒中,存放於安全隱密位置,防止幼童任意遊玩。

After finishing the fire practice, make sure there is not BB bullet left in the barrel, take all reminding BB bullet from the magazine, release the gas completely, packing the pistol, Magazine, BB bullets separately in the pack and store it at the safety place where the kid is unable to reach.

8 射擊 SHOOTING

- 將填入瓦斯及BB彈完成之彈匣裝入槍身中
Insert the gas filled and bullet loaded magazine into the frame receiver
- 也可以先扳下擊鎚瞄準射擊(複動模式)
Pull down the hammer and take aim (repeated action).
- 瞄準目標(開保險)扣扳機射擊
Aim the target, release the thumb safety, and pull the trigger to fire

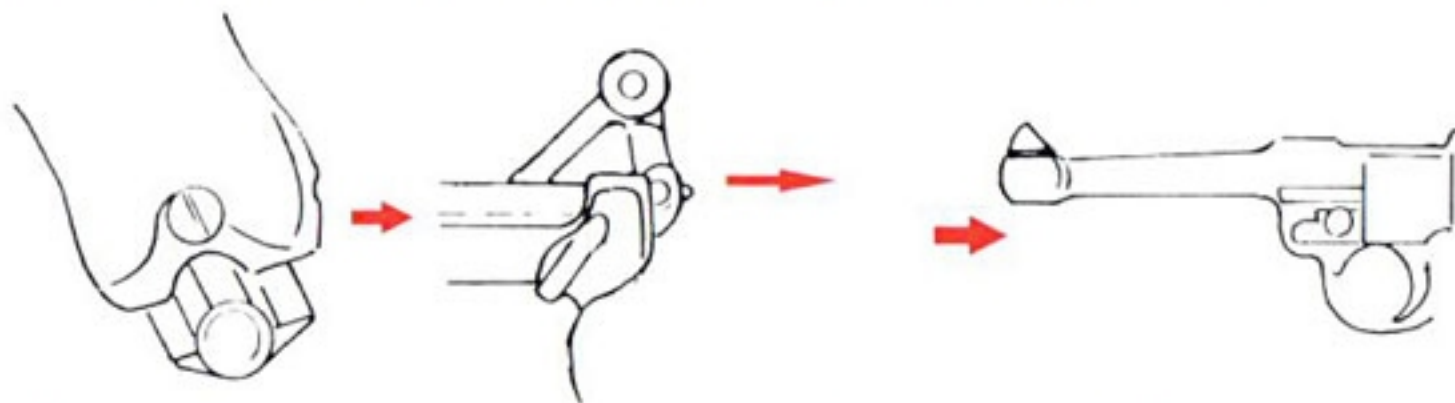

- 初次裝填彈擊發時需先將滑套後拉使其BB彈上膛,擊扣扳機即可發射
注意:填充子彈以14+1發為限
BB彈發射完畢,滑套定位於後方此為無子彈之狀態,如欲繼續射擊填充子彈後下按滑套保險後上膛

When the slide is pulled back and released forward, the bullet is load-ed in the firing chamber, press the trigger to fire the loaded bullet.

Attention: The maximum containment for a magazine is 15 rounds. After the last BB bullet is fired, the slide will be retained in the back position, it means an empty magazine condition. If you want to resume the firing, insert a new fully loaded magazine, press the slide stop to release the slide and to reload the bullet.

⑨ 射擊過程 SHOOTING PROCESS

- 長時間連續發射容易使彈匣過於低溫，影響氣體壓力及子彈初速，此為正常現象非故障所致擊發時請勿倒轉擊發此動作無法使氣體揮發產生霧氣噴出容易導致零件耗損

After a long and continued firing practice, the low temperature of the magazine will cause a reduced gas pressure as well as the low velocity of bullet. It is a normal condition, not a trouble. Never practice the reverse firing for this action renders the gas hardness to volatilize and to produce the atomized gas of ejection which leads the damaged to the parts.



⑩ 射擊完畢 AFTER SHOOTING

- 發射完畢
發射完畢欲收藏時，請將彈匣取出後按下滑套保險，使滑套就定位，擊扣扳機讓擊鎚回復定位
注意：如有子彈請取出

AFTER THE FIRING PRACTICE
After the firing practice, take off the magazine from the stock, push down the slide stop to hold the slide in place and press the trigger to release the hammer.

Attention: Take out any bullet that is inside.

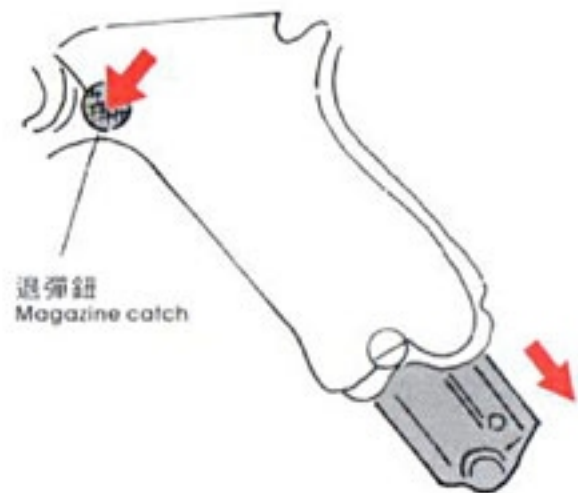

12 HOP UP 說明 APPLICATION OF HOP UP

HOP UP 是讓BB彈於發射管中，因上或下方一端裝置磨擦力較大或較小之彈性物件，使BB彈發射時會有彈體自旋，使整個BB彈的射向呈現一個高拋物線提升射程及密集度。

⚠ 讓 HOP UP 性能安定發揮的條件

- * 選擇大小正確 5.9~5.98~6mm之BB彈，重量最好在0.2~0.25g，太輕則會有上飄情況，太重則會下墜。
- * 拋射力量(瓦斯壓)盡力保持穩定，因為每次一樣的發射力量，才能達到相同的拋射彈道，但使用內充瓦斯壓力本來就不易保持穩定，所以射手只能注意彈匣不可過熱或過冷，維持壓力穩定度。
- * 保持槍枝彈匣機件、清潔、潤滑，維持正常順暢的操作。
- * 外在環境因素=>1.小心風偏，無風狀態下HOP UP是最好發揮環境。
2.環境氣溫不宜低於20°C以下，因瓦斯壓力不夠。

HOP UP is a means to patch up the elastic rubber with high abrasion and low abrasion on the upper side and lower side in the bore, thus forces the fired bullet to create a swivel movement and a higher parabolic trajectory to increase the firing range and hitting concentration.

⚠ How to develop the maximum performance of HOP UP

- * Select very similar size of bullet ranged from 5.9 mm to 5.98 mm or 6 mm in diameter and from 0.2g to 0.25 g in weight. The light weighed bullet would fly in the sky and the heavy-weighed bullet would fall to the ground.
- * The projectile force shall be kept to gain the maximum stability in an attempt to gain an extremely similar parabolic projectile for each firing.
In fact, it is very difficult to maintain the stable pressure of the LG; however, a good shooter shall pay special attention to temperature of the magazine and maintain it not too cold nor too hot so as to have a stable pressure desired.
- * Always keep the magazine part in a neat and working condition and properly lubricated to sustain smooth operation.
- * The external factors =>
 - (1) A tranquil wind is good for development of HOP UP environment.
 - (2) The ambient temperature shall be above 20°C to maintain a stable pressure.

11 HOP-UP 調整 HOP-UP ADJUSTMENT

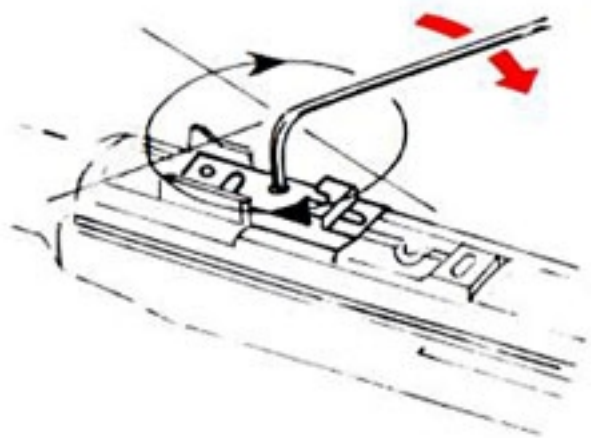

- HOP-UP是以橡皮於BB彈上施以壓力使BB彈自旋上飄以延伸射程會因氣溫、風向、BB彈真圓度及瓦斯推進壓力高低等因素，影響彈道表現的穩定性

The HOP Up adjustment is to apply a compression on the rubber pad against the bullet, when the bullet is fire, it generates a self upward spinning to extend gunshot, which will be effected by the roundness of the bullet, varying gas propellant, climate and wind.

- 以六角扳手調整，鎖緊彈道上升；鬆開彈道下降

Use a hex wrench to adjust. Tightening is to produce upward projectile and loosening is to generate a downward projectile.

HOP UP作動原理是在BB彈待射位置〔入彈橡膠〕上方會有具高磨擦力彈性元件和BB彈上方接觸，使BB彈會在射出時產生順拋射方向旋轉，此構造會有瓦斯壓力較多消耗及初速略減（不明顯）。但是由於其設計原理，所以當壓力（瓦斯壓力）、磨擦力、BB彈〔重量、外型精度〕相關因素任一項改變均會造成彈道變化〔大小程度不一〕。

其中瓦斯槍最大問題仍在瓦斯壓力，操作環境最佳溫度在20°C~30°C，如在此溫度以下操作，彈匣有溫度過冷氣化不良時，可用手握持加溫回升壓力（不可用火或40°C以上溫度加溫）。加溫過高可能導致槍枝故障及危險發生。

⚠ 警告 HOP UP 使用注意事項

1. 試射：調校彈道射擊參照本說明書之[射擊時注意事項]務必切實遵守維護人及自身安全。
2. 操作前務必詳讀本說明書了解熟悉操作及其機構原理。
3. HOP UP 使用下 BB 彈最大飛距可達80m，請注意此範圍內之人事物，不要生誤擊、或引起誤會。
4. 傾斜持槍、槍口無意偏向、側風風偏影響、跳彈反彈，皆會在無預期狀況誤擊他人要小心注意。

HOP UP applies a principle in which an elastic abrasion rubber is posted on the upper part of bore directly contacting with the BB bullet. When fired, the bullet produces a swivel movement along the trajectory course. This design requires more energy and decreases the initial firing velocity but not so significant.

Nevertheless, the change of the trajectory profile is largely dependent on the abrasion and BB bullet (weight and shape).

The key problem of the gas-powered gun lies on the gas pressure. The most optimal temperature to operate the BB Gun is 20°C - 30°C in which even under the condition that the cold would lead to poor evaporation of LG, it can be warmed up by hands to increase the pressure to a desired level. **(Caution: Never use fire to warm up)**

. Overheating would lead to trouble and risk.

⚠ Warning ! Precaution for Applying HOP UP

- (1) Trial fire: The trajectory calibration shall be processed in accordance with the instruction provided in this manual. (Strict maintenance of range rules and personnel safety.)
- (2) Familiarity with Operation and Mechanism of described in this manual.
- (3) Under HOP UP firing, the maximum range is 80m, clean up all material and personnel with this range.
- (4) Holding gun in tilt position, pointing muzzle aimlessly, side wind blowing and ricochet would invite unpredicted accident.

⚠ 注意：

- A. 上述調整方式係在正常操作狀況下的表現，如果相關機件磨耗後可能會有不同的調整數據或失效，此時應到經銷商處更換零件。
- B. BB彈品牌重量不同時會有不同影響，所以請在校正彈道時全使用同一種BB彈，防止誤差加大。
- C. 錯誤調校方式：分解、改造，造成之損壞請使用人自行負責。本公司經銷商仍與以修理但費用由不當操作人負責。

⚠ Attention:

- A. The regulation is processed only under the circumstance that all parts of BB gun are in good condition. The regulation on the worn out parts will result in difference or a failure. Please approach your distributor for consultation and assistance.
- B. Variation in bullet weight creates a variation in influence. In the projectile calibration, fire the bullet of the same lot and same weight.
- C. Wrong regulation: The user is liable for any damage as a result of disassembly, modification and replacement of parts on the **WE** BB gun; however, the distributor will provide assistance in service and repair and the user has to pay the actual cost incurred.

13 分解及保養 DISASSEMBLY AND BASIC MAINTENANCE

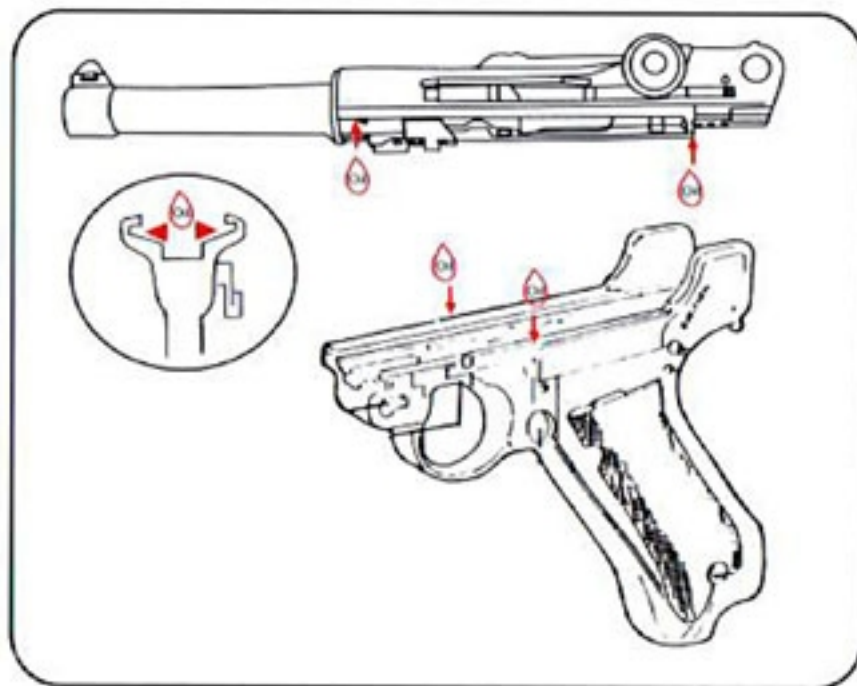
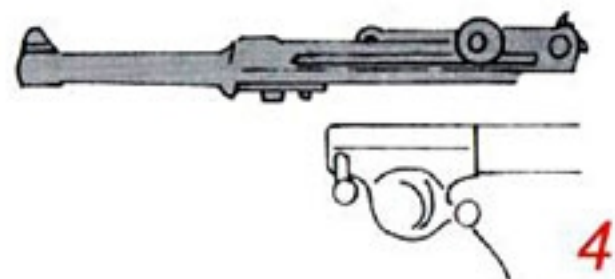
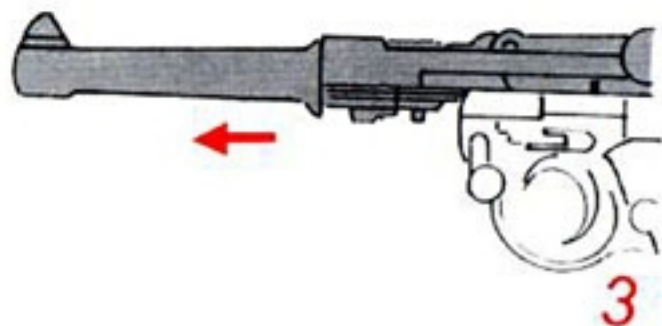
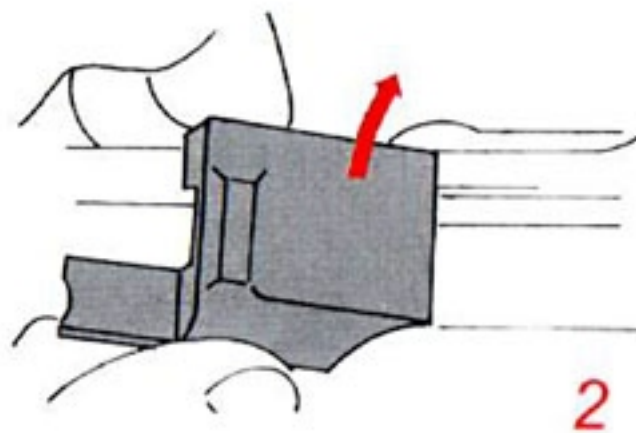
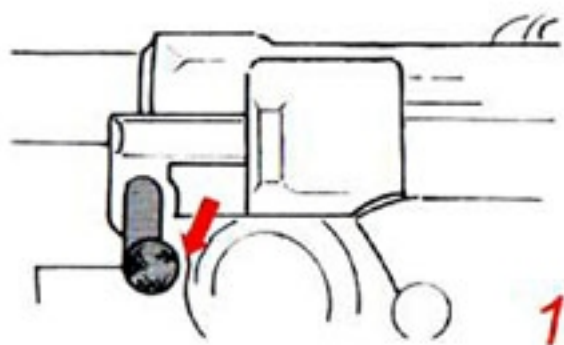

槍枝狀況	原因	處理方法
無法動作	關閉保險	將保險解除即可
	彈匣瓦斯過多	由充氣口或出氣閥向下按壓釋放少量氣體即可 注意:釋放氣體時不可對準火源以及人畜
	彈匣瓦斯不足或特別低溫之情況	填充適量瓦斯氣體即可
	不明原因	請至購買之經銷店維修
無法出彈	BB彈變形	請勿選用使用過和選用劣質BB彈
	彈道孔內有異物	彈匣上彈道內BB彈擠壓卡住或有異物阻塞將雜物清除即可
滑套無法回復定位	給彈結構部份損傷	請至購買之經銷店維修
	給彈口附近有異物阻塞	將異物清除即可
BB彈發射時滑套動作不順	氣溫過低(冬季時)	將彈匣放置室內待溫度回復方可使用 建議使用兩個彈匣交替使用
	彈匣瓦斯不足(1個彈匣長時間使用或連續快速發射,造成快速冷結冰)	
	彈匣氣壓不足	填充瓦斯即可
	擊發結構損壞	請至購買之經銷店維修
	氣密橡膠摩擦破損	
	運動之潤滑不夠	請參考潤滑作業程序
BB彈射程不夠	入彈橡膠破損	請至購買之經銷店維修
	彈簧彈性疲乏	
	出氣口結構損壞	

Condition	Causes	Correction
No action	Safety is locked	Release the safety
	Too much gas	Press the refill inlet or the drain valve to break out an adequate amount of gas. Caution: Never aim the discharged gas to a fire, animal or person.
	Insufficient gas filled or at a very low temperature.	Inject an adequate amount of gas into the gun.
	Unknown reason	Please contact our distributor.
The BB bullet does not eject out of the barrel	Deformed BB bullet	Use the standard BB bullet only.
	The barrel is clogged with extraneous material	Remove the extraneous material from the barrel.
The slide fails to return to the position	An extraneous material jams at the front end of the barrel	Remove the extraneous material
The motion of the slide is not smooth while firing BB bullet	The ambient temperature is too low (in winter)	Place the magazine indoor to recover the temperature. It is recommended to prepare two magazines.
	Insufficient gas in the magazine (A long and continued firing causes quick cooling and frozen)	
	Low gas pressure in the magazine	Refill the gas
	The trigger mechanism is out of work	Please contact our distributor.
	The air-tight rubber seal is worn out or damaged	
	Poor lubrication	Poor use adequate lubricating oil.
Short projectile	The rubber seal is damaged	Please contact our distributor.
	The spring fatigue	
	The gas discharging mechanism is broken	

14 爆炸圖 EXPLOSION

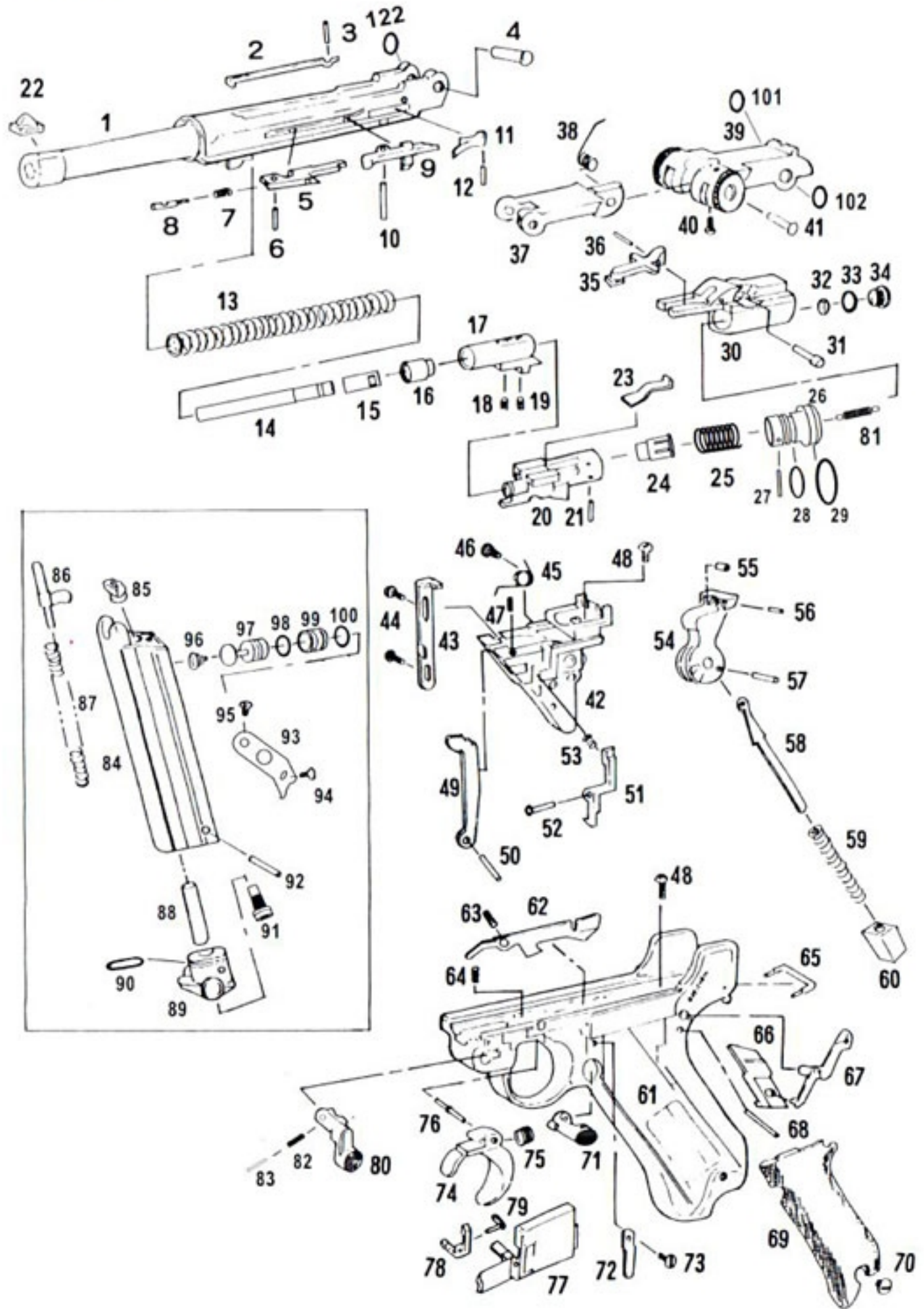

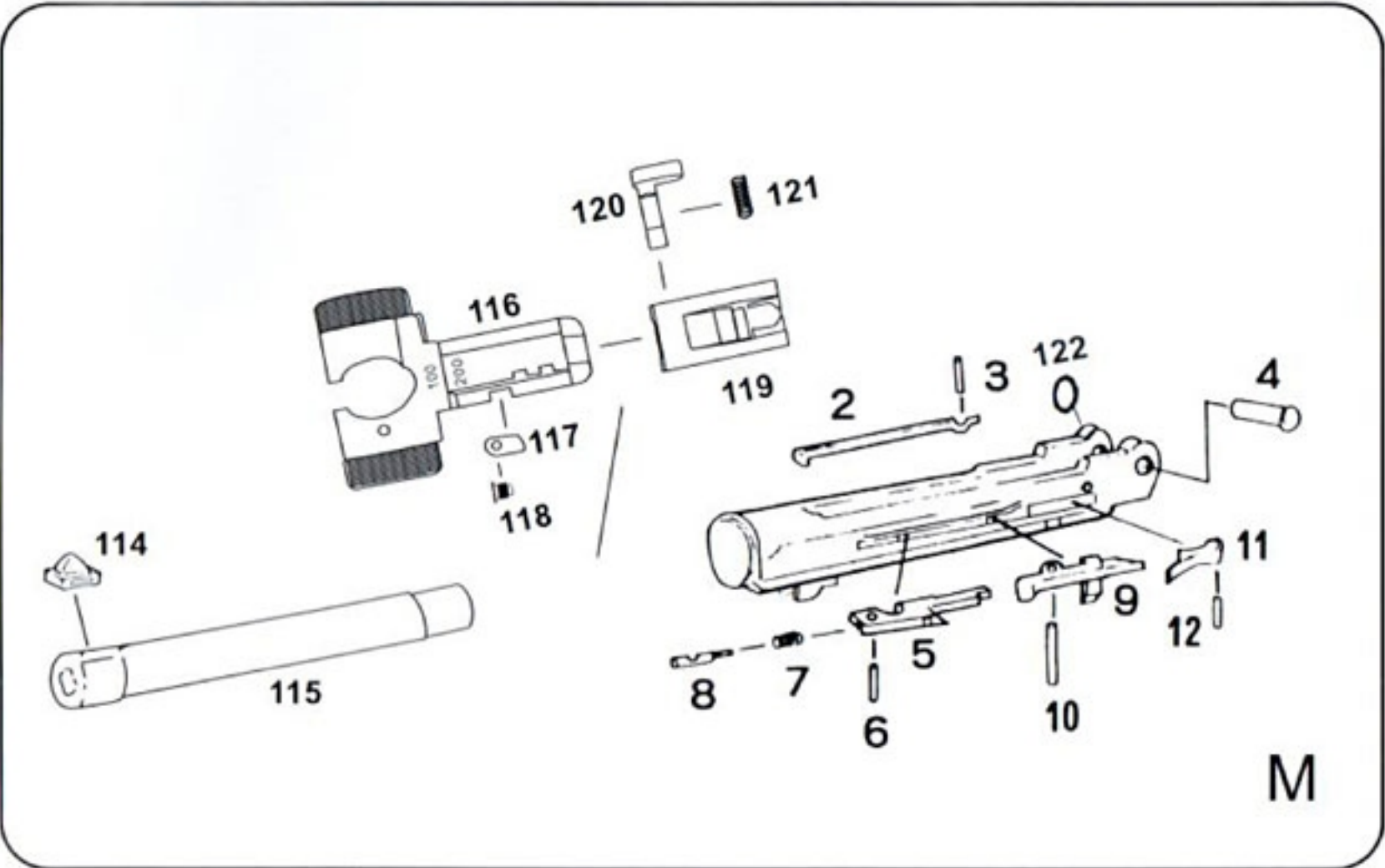
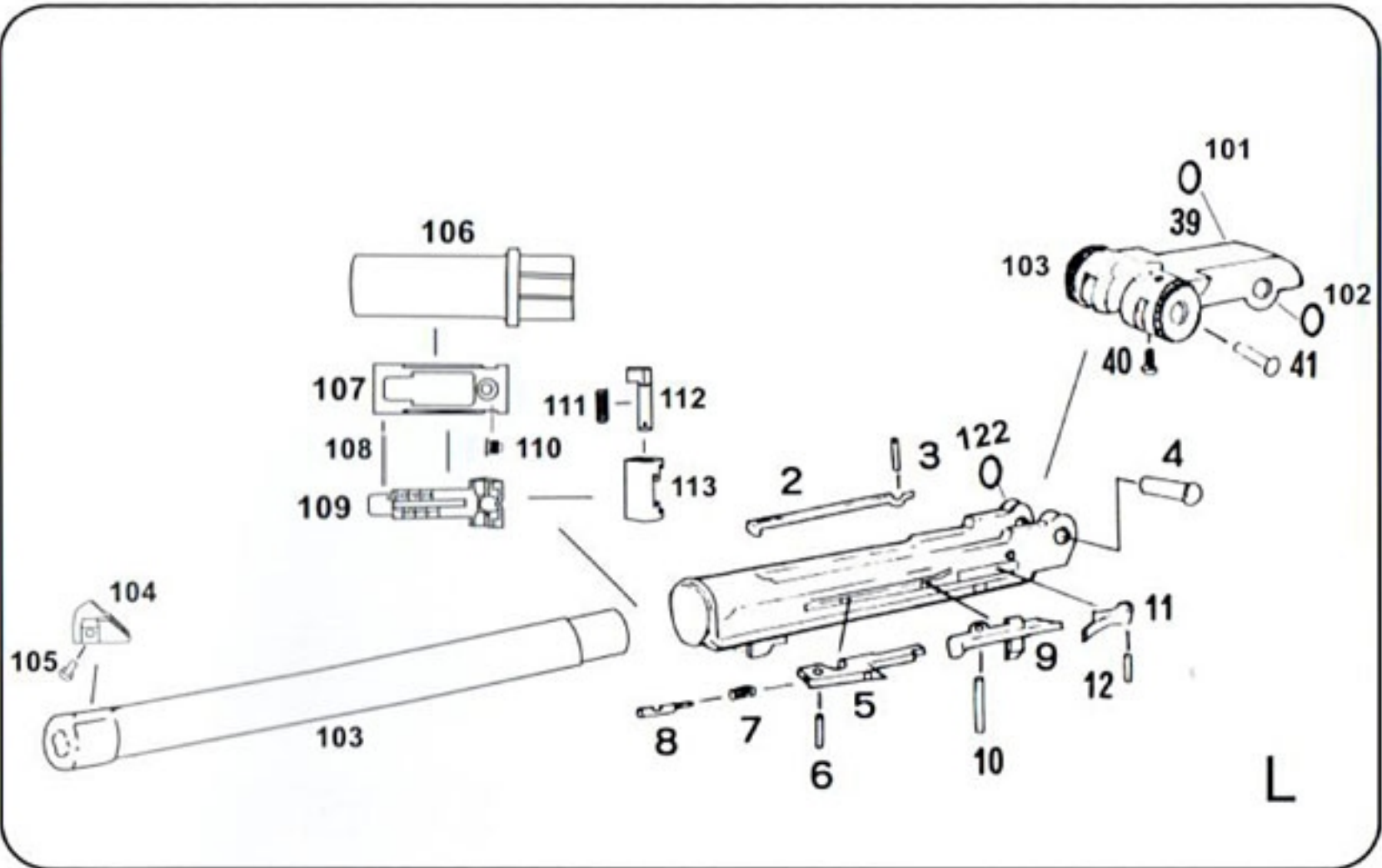

警告

★正確使用空氣軟槍，可享受愉快的射擊，但是錯誤的使用方法非常危險，務必遵守下列注意事項

□ Caution!













▲ PRECAUTION

NE PAS UTILISER D'AUTRES
PROJECTILEE QUE CEUX FOURNIS.

△ VORSICHT

Ausschiesslich fur diese Pistole bestimmte
Munition verwenden.(5.5mm Kunststoffkugeln)

○ Fare attenzione

<p> ★射擊時最好戴護目鏡</p> <p></p> <p><input type="checkbox"/> Be sure to wear shooting glasses or Goggle when shooting.</p> <p><input type="checkbox"/> Toujours porter des lunettes de tir ou de protection quand vous tirez.</p> <p><input type="checkbox"/> Zum Schiessen stets eine Schutzbrille tragen.</p> <p><input type="checkbox"/> Asegurese de llevar puestas las gafas de proteccion cuando dispare.</p> <p><input type="checkbox"/> Assicurarsi di indossare lenti di Protezione quando si spara</p>	<p></p> <p>★不用時要把槍置於高處 (小孩拿不到的高處)</p> <p><input type="checkbox"/> Put the gun beyond the reach of kids.</p> <p><input type="checkbox"/> Tenir hors de portee des enfants.</p> <p><input type="checkbox"/> Pistole immer kindersicher aufbewahren.</p> <p><input type="checkbox"/> Ponga la pistola fuera del alcance de los ninos.</p> <p><input type="checkbox"/> Tenere fuori Dalla portata dei bambini.</p>
<p>★不可用眼睛探視槍</p> <p></p> <p><input type="checkbox"/> Don't peep at the muzzle.</p> <p><input type="checkbox"/> Ne jamais regarder dans le canon.</p> <p><input type="checkbox"/> Nie in den lauf schauen.</p> <p><input type="checkbox"/> Jamas mire por el canon</p> <p><input type="checkbox"/> Non guardare mai dentro la canna.</p> <p></p>	<p>★不可朝人射擊</p> <p></p> <p><input type="checkbox"/> Don't aim at people even if it is unloaded.</p> <p><input type="checkbox"/> Ne jamais viser quelqu'un meme si votre pistolet est vide.</p> <p><input type="checkbox"/> Auch bei spiel-und Sportwaffen besteht Verletzungsgefahr. Auch ungeladen nie auf einen Menschen oder ein Tier richten!</p> <p><input type="checkbox"/> No apunte a personas, incluso descargado.</p> <p><input type="checkbox"/> Non puntare mai verso le persone anche se la pistola scarica.</p> <p></p>
<p>★射擊的瞬間，才可以把手指接近扳機擊扣</p> <p></p> <p><input type="checkbox"/> Don't touch the trigger until the moment of shooting.</p> <p><input type="checkbox"/> Ne jamais appuyer sur la gachette le rearmement.</p> <p><input type="checkbox"/> Abzug erst dann beruhren,wenn Sie zum Schiessen bereit sind.</p> <p><input type="checkbox"/> No toque el gatillo hasta el momento del disparo.</p> <p><input type="checkbox"/> Non toccare il grilletto fino al momento di sparare.</p>	<p>★確定射擊的方向均安全後才可以射擊</p> <p></p> <p><input type="checkbox"/> After making sure that there is nobody nearby.</p> <p><input type="checkbox"/> Toujours etre sur qu'il n y a personne dans la trajectoire de votre tir.</p> <p><input type="checkbox"/> Vergewissern Sie sich vor dem Schiessen stets, dass niemand getroffen werden kann.</p> <p><input type="checkbox"/> Antes de apuntar aseguese que no hay nadie cerca.</p> <p><input type="checkbox"/> Assicurarsi semper che non ci sia nessuno sulla tralettoria di tiro.</p>
<p>★避免粗魯的動作，發生危險</p> <p></p> <p><input type="checkbox"/> Avoid a rough operation.</p> <p><input type="checkbox"/> Ne jamais jeter le pistolet quand il est arme.</p> <p><input type="checkbox"/> Geladene Waffe stets mit Respekt Behandln. Nicht werfen oder unsanft Jandhaben.</p> <p><input type="checkbox"/> No tire ni lance la pistola, se puede disparar.</p> <p><input type="checkbox"/> Evitare azioni brusche.</p> <p></p>	<p>★不使用時，應將彈匣取出，並取下子彈</p> <p><input type="checkbox"/> When the gun is not in use, remove the magazine and unload BB pellets.</p> <p><input type="checkbox"/> Quand vous ne l'utilisez plus,bien Faire attention de retirer le chargeur et de le desarmer.</p> <p><input type="checkbox"/> Zum Aufbewahren Magazin entfernen und Kugeln herausnehmen.</p> <p><input type="checkbox"/> Cuando no se este utilizando la pistola, saque todas las bolas.</p> <p><input type="checkbox"/> Quando l'arma non e in uso, estrarre il caricatore e scaricare i pallini.</p> <p></p>